

## 4001 4011 4021

### End Suction Frame Mounted Centrifugal Pumps

Capacities to 1500 GPM  
Heads to 250 Feet  
1" - 6" Discharge

Deming End Suction Centrifugal pumps are designed to handle a wide range of fluids. All pumps are furnished with right hand rotation as standard, left hand rotation (counter-clockwise) optional. Pumps are available in the following sizes:

Fig. 4001 - 1, 1½, 2½

Fig. 4011 - 1¼S, 1½S, 2S, 1½M, 2M, 3M, 4M

Fig. 4021 - 1½L, 1½M, 2M, 3M, 4M, 5M, 5MS

Fig. 4021H - 1¼S, 1½S, 2S, 2M, 3M, 5M

#### Semi-Open Impeller:

Impeller design permits passage of dirty liquids and/or liquids containing foreign material. Running clearance between suction side of impeller and casing is adjustable to regulate capacity or compensate for wear. This axial adjustment feature is standard on all sizes. The 4000 Series impellers have wiping vanes on balance side and are suitable for handling liquids with lime, chips, or other similar solids, which tend to coat metal surfaces or clog space between casing and impeller.

**NOTE:** Wiping vanes are not available on Fig. 4021H, Size 6ML

Available with packed stuffing box or mechanical seals in single, single with choker ring & double seal configurations.

#### FEATURES:

- Packing Box or Mechanical Seal
- Adjustable Impeller (1½S or 2S)
- All Iron
- Bronze Fitted
- All Bronze
- Stainless Steel Impellers

Suction Side



Balance Side



# DEMING®

by Crane Pumps & Systems, Inc.

## Design Features:

1. Frame - Heavy duty cast iron with precision bore provides rigid support for rotating assembly.
2. Shaft - Large diameter shaft supported by two widely spaced ball bearings provides smooth quiet operation.
3. Shaft Adjusting Nut - Permits axial adjustment of impeller - for regulation of capacity and head and to compensate for wear without dismantling pump.
4. Stuffing Box - Furnished as standard with packing rings, lantern ring and a solid gland. Seal heads are used for mechanical seals.
5. Liquid End - Three-piece assembly with separate suction head permits easy access to impeller, low cost maintenance. Standard cast iron construction designed for working pressure of 150 psi. Can be manufactured of other materials such as (AI, AB, BF) to meet special applications without changing power end.
6. Impeller - Semi-open adjustable impeller with extra heavy vanes gives outstanding performance and wear resistance. Impeller keyed to shaft with

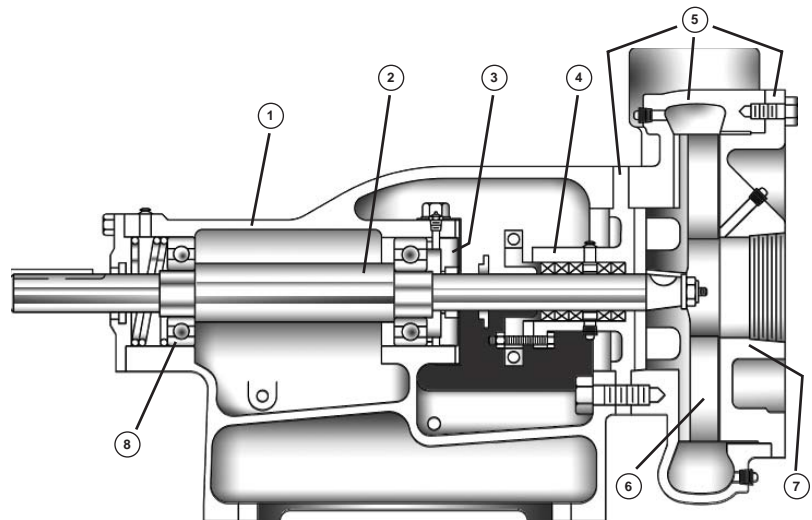

- precision taper fit to assure easy impeller removal and perfect alignment.
7. Suction Head - Separately removable, permits inspection and servicing without disturbing discharge piping or pump alignment.
  8. Bearings - Two widely spaced ball bearings provide solid shaft support. Fig. 4011 frame has a double row bearing at the stuffing box end. Fig. 4021H frame has larger shaft with double row

bearings at both ends.

## Interchangeability:

Figs. 4011, 4021, and 4021H power frames are each suitable for several sizes of liquid ends. In addition, Figs. 4011, 4021, and 4021H liquid ends thru 3" are interchangeable. This permits 4011 liquid ends to be assembled on 4021 power frames thus providing a much heavier pump for heavy duty service.

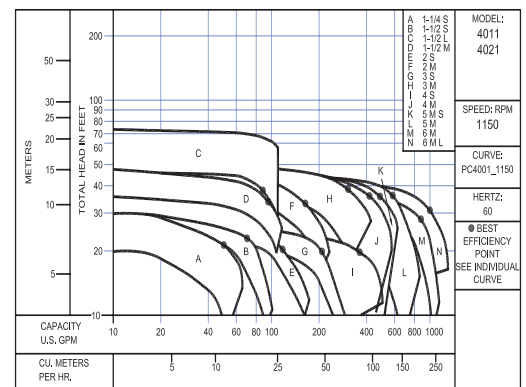
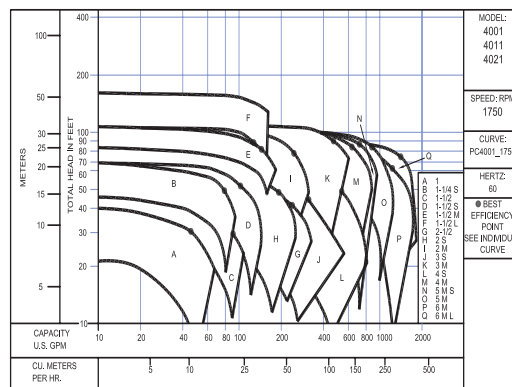
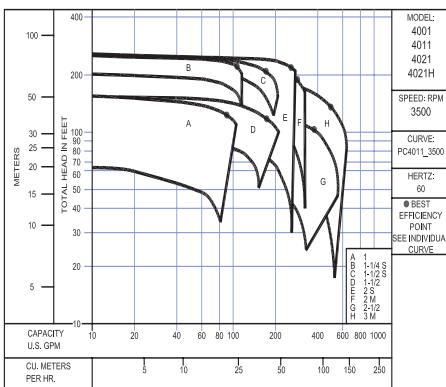

PUMPS & SYSTEMS

[www.cranepumps.com](http://www.cranepumps.com)

**Crane Pumps & Systems**  
420 Third Street  
Piqua, Ohio 45356  
(937) 778-8947  
Fax (937) 773-7157

**Crane Pumps & Systems Canada**  
83 West Drive  
Brampton, Ont. Canada L6T 2J6  
(905) 457-6223  
Fax (905) 457-2650



© 2008 Crane Pumps & Systems, Inc.  
A Crane Co. Company  
Printed in U.S.A.  
D4011BRO - Rev. A (6/09)

